

Инструменты для CAD/CAM систем

Tools for CAD/CAM systems

Фирма NTI, как инновационный производитель высококачественных вращающихся инструментов, к интернациональной выставке стоматологической продукции «IDS 2017» предлагает новый ассортимент продукции инструментов для работы по технологиям CAD/CAM, тем самым, фирма оправдывает свое собственное требование к комплексному предложению вращающихся инструментов. Ассортимент продукции подходит для ЧПУ-фрезерных станков важнейших изготовителей и пригоден для работы с различными материалами.

Самые современные производственные процессы и передовое оборудование гарантируют высокое качество и прекрасную продукцию.

As an innovative manufacturer of high-quality rotary dental instruments NTI is launching a new range of CAD/CAM tools for the IDS 2017 to satisfy our claim of being a full-service provider. The range is suitable for machines from leading manufacturers in the CNC milling machine sector and for different materials. The latest production processes and high-tech machines guarantee highest quality and perfect products.

Возможности заказа • How to order

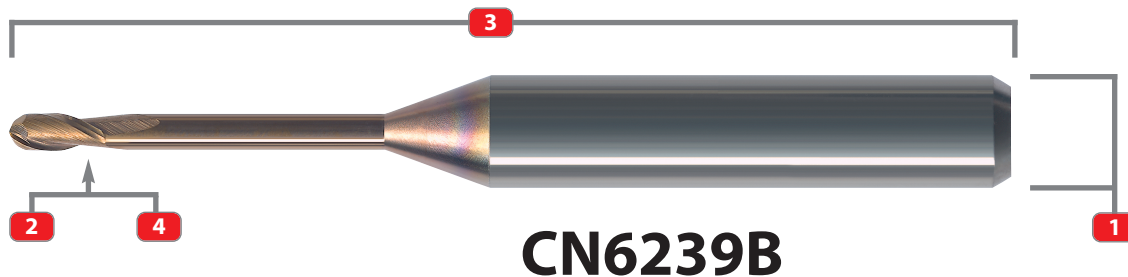

CN6239B

	1	2	3	4
CN	6	2	39	B
Инструменты для CAD/CAM систем/ Tool for CAD/CAM/	Вид хвостовика/ Shank type/ 2 = 2,35 mm 3 = 3 mm 4 = 4 mm 6 = 6 mm	Кол-во лезвий/ Number blades/	инструмент №/ Tool No./	Покрытие/ Coating/

L18

Обозначение различных материалов

Identification of different processing materials

PEEK	Полиэтерэтеркетон/Polyetheretherketone
PMMA	Полиметилметакрилат/Polymethyl methacrylate
Воск/Wax	Воск/Wax
CrCo	Кобальт-хромовый сплав/Chrome cobalt
Ti	Титан/Titanium
ZrO2	Диоксид циркония белый/Zirconia white
Гипс/Plaster	Гипс/Plaster

Покрытие • Coating

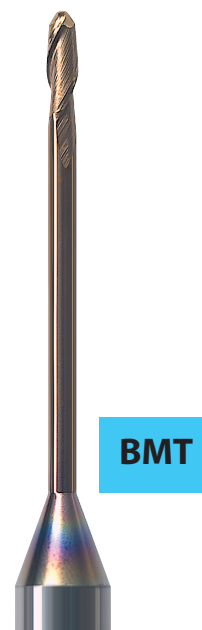

D = BDN-алмазное покрытие

Благодаря BDN-покрытию существенно продлевается срок эксплуатации инструментов и значительно улучшаются поверхности инструментов. Инструменты с данным покрытием предназначены для обработки керамических заготовок из диоксида циркония в частично спеченном состоянии (белые заготовки).

D = BDN diamond coating

The BDN coating massively increases the service life of the instrument and greatly improves the surface quality of the restoration. For processing partially sintered zirconia (white state).

C = DLC-покрытие

Инструменты с DLC-покрытием имеют более высокую твердость и более низкое сопротивление трению для особенно хорошей защиты от абразивного и адгезивного износа, имеют острые лезвия. Предназначаются для обработки циркониевой керамики.

C = DLC coating

The DLC coating with high hardness and low friction resistance for particularly good abrasive and adhesive wear protection as well as sharp cutting edges. Also specifically for zirconia processing.

B = BMT-покрытие

B=BMT-покрытие гарантирует особо высокую прочность, имеет острые лезвия и хороший отвод стружки для продолжительной эксплуатации. Инструменты с данным покрытием предназначены для обработки особо прочных материалов, с которых сложно снимать стружку таких, как кобальт-хромовый сплав и титан.

B = BMT coating

The BMT coating guarantees particularly high wear-resistance with sharp cutting edges and good chip removal for long instrument servelives. For processing high-strength and difficult-to machine materials such as CoCr and titanium.

Перечень инструментов по совместимости с группами изготовителей

Summary of tools according to compatible manufacturing groups

Группа изготовителей/ Manufacturer group/ Хвостовик/Shank Ø 3 mm	A	Группа изготовителей/ Manufacturer group/ Хвостовик/Shank Ø 3 mm	B	Группа изготовителей/ Manufacturer group/ Хвостовик/Shank Ø 3 mm	C	Группа изготовителей/ Manufacturer group/ Хвостовик/Shank Ø 3 mm	D
Amann Girrbach		Amann Girrbach		Amann Girrbach		Amann Girrbach	
Datron	●	Datron		Datron		Datron	
DCS	●	DCS		DCS		DCS	
DMG	●	DMG		DMG		DMG	
DT Finocam		DT Finocam	●	DT Finocam	●	DT Finocam	
Goldquadrat = R+K	●	Goldquadrat = R+K		Goldquadrat = R+K		Goldquadrat = R+K	
Hinrichs Dental Mill 4		Hinrichs Dental Mill 4	●	Hinrichs Dental Mill 4		Hinrichs Dental Mill 4	
imes-icore	●	imes-icore		imes-icore		imes-icore	
Impression VHF		Impression VHF	●	Impression VHF	●	Impression VHF	●
MB	●	MB		MB		MB	
MC Dental Smart mill Plus		MC Dental Smart mill Plus	●	MC Dental Smart mill Plus	●	MC Dental Smart mill Plus	
Mikron	●	Mikron		Mikron		Mikron	
Primacon	●	Primacon		Primacon		Primacon	
Röders	●	Röders		Röders		Röders	
Roland		Roland		Roland		Roland	
Schütz Tizian Cut 5	●	Schütz Tizian Cut 5	●	Schütz Tizian Cut 5	●	Schütz Tizian Cut 5	
Wissner	●	Wissner		Wissner		Wissner	
Wieland Mini		Wieland Mini	●	Wieland Mini	●	Wieland Mini	
Yenadent		Yenadent		Yenadent		Yenadent	
ZFX Mill Inhouse		ZFX Mill Inhouse	●	ZFX Mill Inhouse		ZFX Mill Inhouse	
Zirkonzahn		Zirkonzahn		Zirkonzahn		Zirkonzahn	

Группа изготовителей/ Manufacturer group/ Хвостовик/Shank Ø 6 mm	E	Группа изготовителей/ Manufacturer group/ Хвостовик/Shank Ø 6 mm	F	Группа изготовителей/ Manufacturer group/ Хвостовик/Shank Ø 6 mm	G
Amann Girrbach		Amann Girrbach		Amann Girrbach	
Datron	●	Datron		Datron	
DCS	●	DCS		DCS	
DMG	●	DMG		DMG	
DT Finocam		DT Finocam		DT Finocam	
Goldquadrat = R+K	●	Goldquadrat = R+K		Goldquadrat = R+K	
Hinrichs Dental Mill 4		Hinrichs Dental Mill 4		Hinrichs Dental Mill 4	
imes-icore		imes-icore	●	imes-icore	
Impression VHF		Impression VHF		Impression VHF	
MB	●	MB		MB	
MC Dental Smart mill Plus		MC Dental Smart mill Plus		MC Dental Smart mill Plus	
Mikron	●	Mikron		Mikron	
Primacon	●	Primacon		Primacon	
Röders	●	Röders		Röders	
Roland		Roland		Roland	
Schütz Tizian Cut 5		Schütz Tizian Cut 5	●	Schütz Tizian Cut 5	
Wissner	●	Wissner		Wissner	
Wieland Mini		Wieland Mini		Wieland Mini	
Yenadent		Yenadent		Yenadent	
ZFX Mill Inhouse		ZFX Mill Inhouse		ZFX Mill Inhouse	
Zirkonzahn		Zirkonzahn		Zirkonzahn	●

Хвостовик/Shank \varnothing 3 mm – Лезвия/Blades 1

Изготовитель **A**

Manufacturers/

Datron, DCS, DMG,
Goldquadrat = R+K,
imes-icore, MB, Mikron,
Primacon, Röders,
Schütz Tizian Cut 5,
Wissner

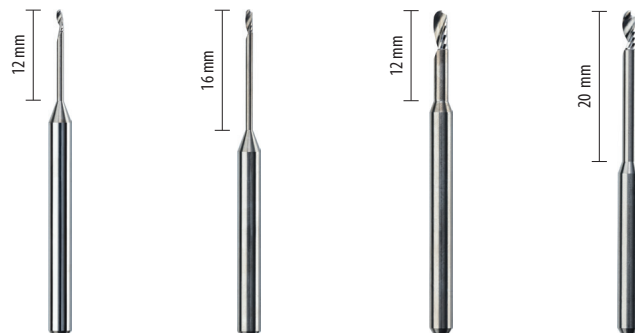

Размер/Size \varnothing mm	1,0	1,0	2,0	2,0
Длина Рабочая часть/ Length working section/ mm	12	16	12	20
Общая длина/Overall length/ mm	43	43	43	43

Для обработки следующих материалов/ for machining the following materials	PEEK	PEEK	PEEK	PEEK
	PMMA	PMMA	PMMA	PMMA
	Воск/Wax	Воск/Wax	Воск/Wax	Воск/Wax



REF	CN3101	CN3102	CN3106	CN3108
-----	--------	--------	--------	--------

Изготовитель **B**

Manufacturers/

DT Finocam,
Hinrichs Dental Mill 4,
Impression VHF,
MC-Dental Smart Mill Plus,
Schütz Tizian Cut 5,
Wieland Mini,
ZFX Mill Inhouse

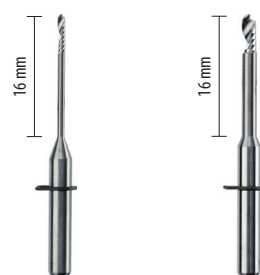

Размер/Size \varnothing mm	1,0	2,0
Длина Рабочая часть/ Length working section/ mm	16	16
Общая длина/Overall length/ mm	35	35

Для обработки следующих материалов/ for machining the following materials	PEEK	PEEK
	PMMA	PMMA
	Воск/Wax	Воск/Wax



REF	CN3103	CN3107
-----	--------	--------

Хвостовик/Shank \varnothing 3 mm – Лезвия/Blades 2

Изготовитель **A**
Manufacturers/

Datron, DCS, DMG,
Goldquadrat = R+K,
imes-icore, MB, Mikron,
Primacon, Röders,
Schütz Tizian Cut 5,
Wissner

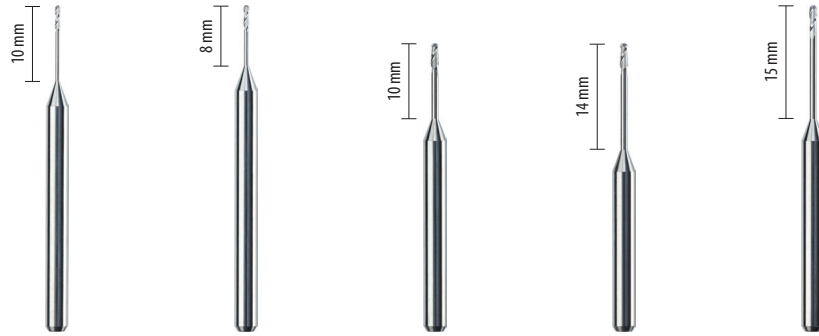

Размер/Size \varnothing mm	0,7	0,7	1,0	1,0	1,0
Длина Рабочая часть/ Length working section/ mm	10	8	10	14	15
Общая длина/Overall length/ mm	43	43	38	38	43
Для обработки следующих материалов/ for machining the following materials	PEEK	PEEK	PEEK	PEEK	PEEK
	PMMA	PMMA	PMMA	PMMA	PMMA
	CrCo	CrCo	CrCo	CrCo	
	Ti	Ti	Ti	Ti	
	ZrO2	ZrO2	ZrO2	ZrO2	ZrO2



REF	CN3212	CN3211	CN3215	CN3216	CN3219
-----	--------	--------	--------	--------	--------

Изготовитель **A**
Manufacturers/

Datron, DCS, DMG,
Goldquadrat = R+K,
imes-icore, MB, Mikron,
Primacon, Röders,
Schütz Tizian Cut 5,
Wissner

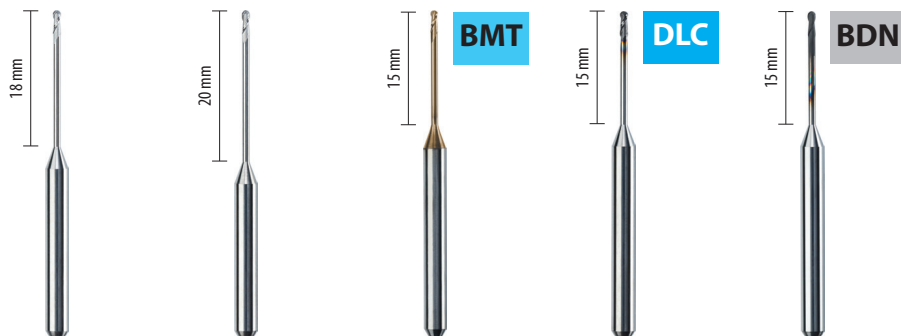

Размер/Size \varnothing mm	1,0	1,0	1,0	1,0	1,0
Длина Рабочая часть/ Length working section/ mm	18	20	15	15	15
Общая длина/Overall length/ mm	43	43	43	43	43
Для обработки следующих материалов/ for machining the following materials	PEEK	PEEK	PEEK	PEEK	
	PMMA	PMMA	PMMA	PMMA	
	CrCo	CrCo	CrCo	CrCo	
	Ti	Ti	Ti	Ti	
	ZrO2	ZrO2	ZrO2	ZrO2	ZrO2



REF	CN3232	CN3233	CN3221B	CN3224C	CN3220D
-----	--------	--------	---------	---------	---------

Хвостовик/Shank \varnothing 3 mm – Лезвия/Blades 2

Изготовитель A
 Manufacturers/

Datron, DCS, DMG,
 Goldquadrat = R+K,
 imes-icore, MB, Mikron,
 Primacon, Röders,
 Schütz Tizian Cut 5,
 Wissner

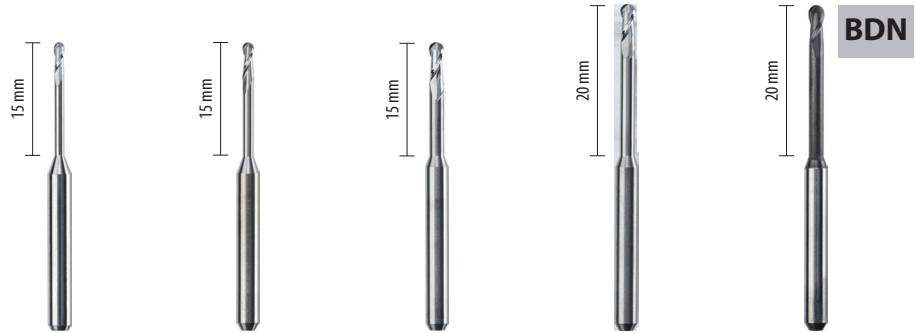

Размер/Size \varnothing mm	1,3	1,5	2,0	2,0	2,0
Длина Рабочая часть/ Length working section/ mm	15	15	15	20	20
Общая длина/Overall length/ mm	38	38	38	43	43
Для обработки следующих материалов/ for machining the following materials	PEEK	PEEK	PEEK	PEEK	
	PMMA	PMMA	PMMA	PMMA	
	CrCo	CrCo	CrCo	CrCo	
	Ti	Ti	Ti	Ti	
	ZrO2	ZrO2	ZrO2	ZrO2	ZrO2



REF	CN3237	CN3238	CN3242	CN3244	CN3245D
-----	--------	--------	--------	--------	---------

Изготовитель A
 Manufacturers/

Datron, DCS, DMG,
 Goldquadrat = R+K,
 imes-icore, MB, Mikron,
 Primacon, Röders,
 Schütz Tizian Cut 5,
 Wissner

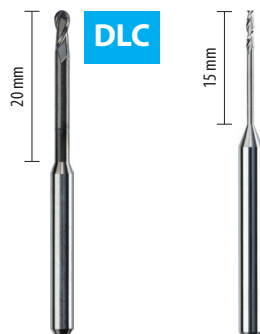

Размер/Size \varnothing mm	2,0	1,0
Длина Рабочая часть/ Length working section/ mm	20	15
Общая длина/Overall length/ mm	43	43
Для обработки следующих материалов/ for machining the following materials	PEEK	PEEK
	PMMA	PMMA
		Бокс/Wax
	ZrO2	ZrO2



REF	CN3248C	CN3223
-----	---------	--------

Хвостовик/Shank \varnothing 3 mm – Лезвия/Blades 2

Изготовитель **B**
Manufacturers/

DT Finocam,
 Hinrichs Dental Mill 4,
 Impression VHF,
 MC-Dental Smart Mill Plus,
 Schütz Tizian Cut 5,
 Wieland Mini,
 ZFX Mill Inhouse

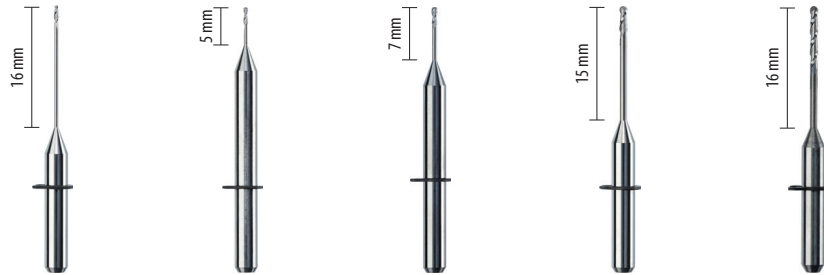

Размер/Size \varnothing mm	0,6	0,6	0,7	1,0	1,0
Длина Рабочая часть/ Length working section/ mm	16	5	7	15	16
Общая длина/Overall length/ mm	35	35	35	35	35
Для обработки следующих материалов/ for machining the following materials	PEEK	PEEK	PEEK	PEEK	PEEK
	PMMA	PMMA	PMMA	PMMA	PMMA
	ZrO2	ZrO2	ZrO2	ZrO2	ZrO2



REF	CN3207	CN3203	CN3209	CN3235	CN3225
-----	--------	--------	--------	--------	--------

Изготовитель **B**
Manufacturers/

DT Finocam,
 Hinrichs Dental Mill 4,
 Impression VHF,
 MC-Dental Smart Mill Plus,
 Schütz Tizian Cut 5,
 Wieland Mini,
 ZFX Mill Inhouse

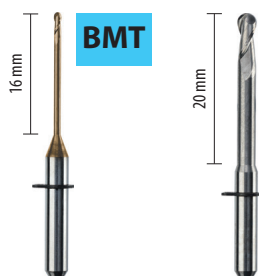

Размер/Size \varnothing mm	1,0	2,5
Длина Рабочая часть/ Length working section/ mm	16	20
Общая длина/Overall length/ mm	35	35
Для обработки следующих материалов/ for machining the following materials	PEEK	PEEK
	PMMA	PMMA
	ZrO2	ZrO2



REF	CN3226B	CN3260
-----	---------	--------

Хвостовик/Shank \varnothing 3 mm – Лезвия/Blades 2

Изготовитель C
Manufacturers/

DT Finocam,
Impression VHF,
MC-Dental Smart Mill Plus,
Schütz Tizian Cut Smart,
Wieland Mini

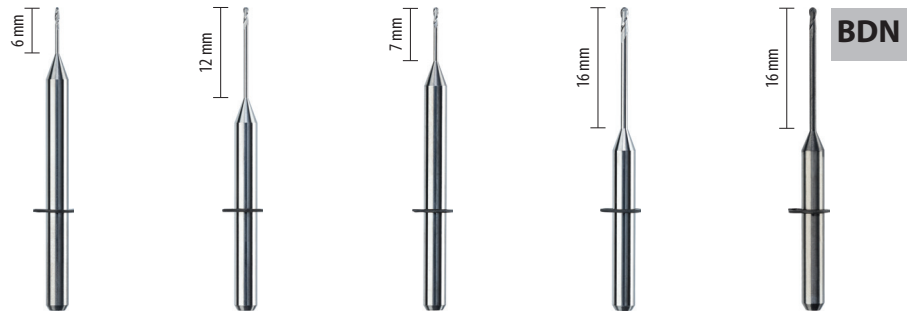

Размер/Size \varnothing mm	0,6	0,7	0,7	1,0	1,0
Длина Рабочая часть/ Length working section/ mm	6	12	7	16	16
Общая длина/Overall length/ mm	40	40	40	40	40
Для обработки следующих материалов/ for machining the following materials	PEEK	PEEK	PEEK	PEEK	
	PMMA	PMMA	PMMA	PMMA	
	ZrO2	ZrO2	ZrO2	ZrO2	ZrO2



REF	CN3204	CN3213	CN3210	CN3227	CN3228D
-----	--------	--------	--------	--------	---------

Изготовитель C
Manufacturers/

DT Finocam,
Impression VHF,
MC-Dental Smart Mill Plus,
Schütz Tizian Cut Smart,
Wieland Mini

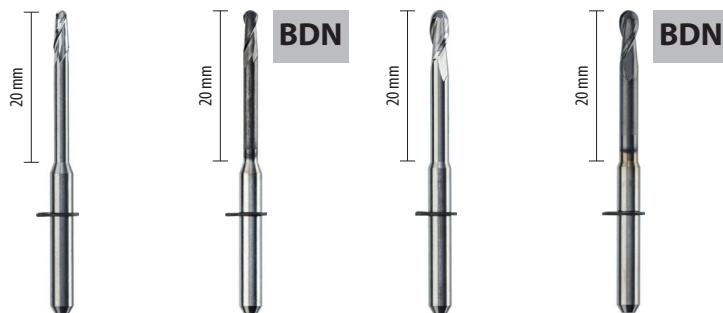

Размер/Size \varnothing mm	2,0	2,0	2,5	2,5
Длина Рабочая часть/ Length working section/ mm	20	20	20	20
Общая длина/Overall length/ mm	40	40	40	40
Для обработки следующих материалов/ for machining the following materials	PEEK		PEEK	
	PMMA		PMMA	
	ZrO2	ZrO2	ZrO2	ZrO2



REF	CN3246	CN3247D	CN3261	CN3266D
-----	--------	---------	--------	---------

Хвостовик/Shank \varnothing 3 mm – Лезвия/Blades 2

Изготовитель **D**
 Manufacturers/



Impression VHF

Размер/Size \varnothing mm	0,6	1,0	2,0
Длина Рабочая часть/ Length working section/ mm	2	8	12
Общая длина/Overall length/ mm	32	32	32
Для обработки следующих материалов/ for machining the following materials			
	CrCo	CrCo	CrCo
	Ti	Ti	Ti



REF	CN3202	CN3214	CN3241
-----	--------	--------	--------

Хвостовик/Shank \varnothing 3 mm – Лезвия/Blades 3

Изготовитель **B**
 Manufacturers/

DT Finocam,
 Hinrichs Dental Mill 4,
 Impression VHF,
 MC-Dental Smart Mill Plus,
 Schütz Tizian Cut 5,
 Wieland Mini,
 ZFX Mill Inhouse

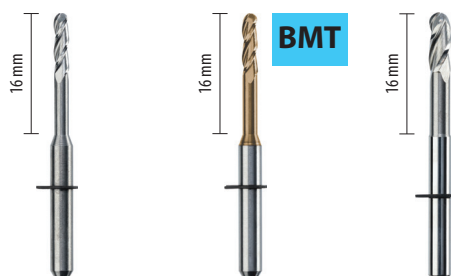

Размер/Size \varnothing mm	2,0	2,0	3,0
Длина Рабочая часть/ Length working section/ mm	16	16	16
Общая длина/Overall length/ mm	35	35	35
Для обработки следующих материалов/ for machining the following materials	PEEK	PEEK	PEEK
	PMMA	PMMA	PMMA
	ZrO2	ZrO2	ZrO2



REF	CN3301	CN3302B	CN3305
-----	--------	---------	--------

Хвостовик/Shank \varnothing 6 mm – Лезвия/Blades 1

Изготовитель **E**
Manufacturers/

Datron, DCS, DMG,
Goldquadrat = R+K,
MB, Mikron, Primacon,
Röders, Wissner



15 mm

Размер/Size \varnothing mm	1,0
Длина Рабочая часть/ Length working section/ mm	15
Общая длина/Overall length/ mm	53

Для обработки следующих материалов/
for machining the following materials

PEEK
PMMA
Воск/Wax

 1

REF CN6101

Изготовитель **F**
Manufacturers/

imes-icore,
Schütz Tizian Cut 5



15 mm

Размер/Size \varnothing mm	1,0
Длина Рабочая часть/ Length working section/ mm	15
Общая длина/Overall length/ mm	53

Для обработки следующих материалов/
for machining the following materials

PEEK
PMMA
Воск/Wax

 1

REF CN6102

Хвостовик/Shank \varnothing 6 mm – Лезвия/Blades 2

Изготовитель **E**
Manufacturers/

Datron, DCS, DMG,
Goldquadrat = R+K,
MB, Mikron, Primacon,
Röders, Wissner



15 mm



15 mm **BDN**



15 mm **BMT**



20 mm



20 mm **BMT**

Размер/Size \varnothing mm	1,0	1,0	1,0	2,0	2,0
Длина Рабочая часть/ Length working section/ mm	15	15	15	20	20
Общая длина/Overall length/ mm	53	53	53	53	53

Для обработки следующих материалов/
for machining the following materials

PEEK		PEEK	PEEK	PEEK
PMMA		PMMA	PMMA	PMMA
CrCo		CrCo	CrCo	CrCo
Ti		Ti	Ti	Ti
ZrO2	ZrO2	ZrO2	ZrO2	ZrO2

 1

REF CN6210 CN6213D CN6215B CN6234 CN6237B

Хвостовик/Shank \varnothing 6 mm – Лезвия/Blades 2

Изготовитель **E**
Manufacturers/

Datron, DCS, DMG,
 Goldquadrat = R+K,
 MB, Mikron, Primacon,
 Röders, Wissner



BDN

Размер/Size \varnothing mm	2,0
Длина Рабочая часть/ Length working section/ mm	20
Общая длина/Overall length/ mm	53

Для обработки следующих
 материалов/
for machining the following materials

ZrO2

 1

REF **CN6235D**

Изготовитель **G**
Manufacturers/

Zirkonzahn



Размер/Size \varnothing mm	1,0
Длина Рабочая часть/ Length working section/ mm	12
Общая длина/Overall length/ mm	50

Для обработки следующих
 материалов/
for machining the following materials

ZrO2

 1

REF **CN6228**

Хвостовик/Shank \varnothing 6 mm – Лезвия/Blades 2

Изготовитель <i>Manufacturers/</i> F imes-icore, Schütz Tizian Cut 5					
	Размер/Size \varnothing mm	1,0	1,0	1,0	2,0
Длина Рабочая часть/ Length working section/mm	15	15	15	20	20
Общая длина/Overall length/mm	53	53	53	53	53
Для обработки следующих материалов/ <i>for machining the following materials</i>	PEEK		PEEK	PEEK	
	PMMA		PMMA	PMMA	
	CrCo		CrCo	CrCo	
	Ti		Ti	Ti	
	ZrO2	ZrO2	ZrO2	ZrO2	ZrO2
REF	CN6211	CN6214D	CN6216B	CN6245B	CN6236D